

Discrete and Continuous Models for Concurrent Systems

5. Advanced Topics

Uli Fahrenberg

LMF, Université Paris-Saclay, France

ISIMM, April 2026

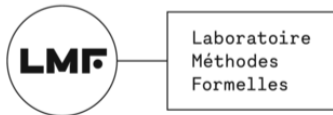

- ① Concurrent Kleene Algebra
- ② Birkhoff Duality & Path Objects
- ③ Geometric Realisation

Monoids, Semirings, Kleene Algebra (Recall, Hopefully)

- a **monoid**: set S , operation \cdot on S , associative with unit $1 \in S$
 - free monoid on Σ : Σ^* ; \cdot is **concatenation**
- a **semiring**: set S , operations $+$ (associative, commutative, unit 0) and \cdot (associative, unit 1), plus distributivity $(x + y)z = xz + yz$ and $z(x + y) = zx + zy$
 - **idempotent** if $x + x = x$
 - free idempotent semiring on Σ : **finite** subsets of Σ^*
 - (powerset lifting; general principle of adding idempotent $+$ to algebraic structure)
- a **Kleene algebra**: idempotent semiring plus (unary) $*$ operation
 - $*$ “computes loops” / “computes least fixed points”
 - (different axiomatisations possible)

Concurrent Kleene Algebra

Definition

A **concurrent monoid** $(S, \cdot, \parallel, 1, \leq)$:

- S set, \cdot and \parallel associative operations with **shared unit** 1
 - \cdot concatenation, \parallel parallel composition
- \leq partial order on S such that \cdot and \parallel are **monotone**
 - $x \leq y \implies x \cdot z \leq y \cdot z$ and $x \parallel z \leq y \parallel z$ etc.
- and such that $(x \parallel y) \cdot (z \parallel w) \leq (x \cdot z) \parallel (y \cdot w)$
 - **lax interchange:**

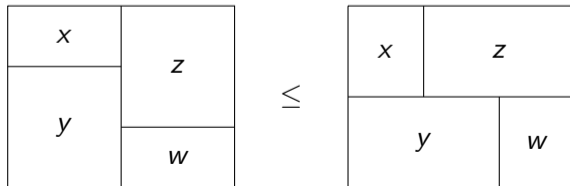

Concurrent Kleene Algebra?

- concurrent monoid: $(S, \cdot, \parallel, 1, \leq)$
- free concurrent monoid on Σ : **series-parallel pomsets**
 - pomsets obtained from $a \in \Sigma$ by **series** and **parallel** composition
- Theorem (old): pomset P is series-parallel iff P contains **no induced N**

Concurrent Kleene Algebra?

- concurrent monoid: $(S, \cdot, \parallel, 1, \leq)$
- free concurrent monoid on Σ : **series-parallel pomsets**
 - pomsets obtained from $a \in \Sigma$ by **series** and **parallel** composition
- Theorem (old): pomset P is series-parallel iff P contains **no induced N**
- but look we have N's:

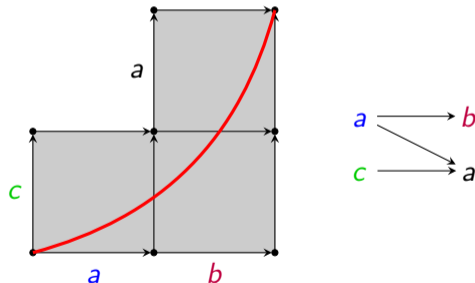

⇒ standard CKA does not seem suited for HDA languages!

Special ipomsets

Definition

An ipomset $(P, <, \dashrightarrow, S, T, \lambda)$ is

- **discrete** if $<$ is empty (hence \dashrightarrow is total)
 - also written ${}_S P_T$
- a **conclist** (“concurrency list”) if it is discrete and $S = T = \emptyset$
- a **starter** if it is discrete and $T = P$
- a **terminator** if it is discrete and $S = P$
- an **identity** if it is both a starter and a terminator



Lemma (Janicki-Koutny 93; reformulated)

An ipomset is interval iff it has a decomposition into discrete ipomsets.

Decompositions

Lemma (Janicki-Koutny 93)

A poset $(P, <)$ is an interval order iff the order defined on its maximal antichains defined by $A \preceq B \iff \forall a \in A, b \in B : b \not< a$ is total.

Corollary

An ipomset is interval iff it has a decomposition into discrete ipomsets.

Lemma

Any discrete ipomset is a gluing of a starter and a terminator. $\begin{bmatrix} \bullet a \\ \bullet b \\ \bullet a \end{bmatrix} = \begin{bmatrix} \bullet a \\ \bullet b \\ \bullet a \end{bmatrix} * \begin{bmatrix} \bullet a \\ \bullet b \\ \bullet a \end{bmatrix}$

Corollary

Any interval ipomset has a decomposition as a sequence of starters and terminators.

$$\left[\begin{array}{ccc} a & \rightarrow & b \\ c & \rightarrow & a \end{array} \right] = \begin{bmatrix} a \bullet \\ c \end{bmatrix} * \begin{bmatrix} \bullet a \\ \bullet a \end{bmatrix} * \begin{bmatrix} b \\ \bullet a \end{bmatrix} = \begin{bmatrix} a \bullet \\ c \bullet \end{bmatrix} * \begin{bmatrix} \bullet a \\ \bullet c \end{bmatrix} * \begin{bmatrix} \bullet a \\ \bullet a \end{bmatrix} * \begin{bmatrix} \bullet a \\ \bullet a \end{bmatrix} * \begin{bmatrix} b \bullet \\ \bullet a \end{bmatrix} * \begin{bmatrix} \bullet b \\ \bullet a \end{bmatrix}$$

Unique decompositions

Notation: **St**: set of starters ${}_S U_U$
Te: set of terminators ${}_U U_T$
Id = **St** \cap **Te**: set of identities ${}_U U_U$
 $\Omega = \text{St} \cup \text{Te}$

Definition

A word $w = (S_1, U_1, T_1) \dots (S_n, U_n, T_n) \in \Omega^+$ is **coherent** if $T_i = S_{i+1}$ for all i .

Definition

A coherent word is **sparse** if proper starters and proper terminators are alternating.

- additionally, all $w \in \text{Id} \subseteq \Omega^+$ are sparse
- so that's $\text{Id} \cup (\text{St} \setminus \text{Id})((\text{Te} \setminus \text{Id})(\text{St} \setminus \text{Id}))^* \cup (\text{Te} \setminus \text{Id})((\text{St} \setminus \text{Id})(\text{Te} \setminus \text{Id}))^*$

Lemma

Any interval ipomset P has a **unique** decomposition $P = P_1 * \dots * P_n$ such that $P_1 \dots P_n \in \Omega^+$ is **sparse**.

Step sequences

Let \sim be the congruence on Ω^+ generated by the relation

$$sUU \cdot uTT \sim sTT \quad sSU \cdot uUT \sim sST$$

- (compose subsequent starters and subsequent terminators)

Definition

A **step sequence** is a \sim -equivalence class of coherent words in Ω^+ .

Lemma

*Any step sequence has a **unique sparse** representant.*

Theorem

The category of interval ipomsets is isomorphic to the category of step sequences.

Categories?

Definition (Category iiPoms)

objects: conlists U (discrete ipomsets without interfaces)

morphisms in $\text{iiPoms}(U, V)$: interval ipomsets P with sources U and targets V

composition: gluing

identities $\text{id}_U = {}_U U_U$

Definition (Category Coh)

objects: conlists U (discrete ipomsets without interfaces)

morphisms in $\text{Coh}(U, V)$: step sequences $[(S_1, U_1, T_1) \dots (S_n, U_n, T_n)]_{\sim}$ with $S_1 = U$ and $T_n = V$

composition: concatenation

identities $\text{id}_U = {}_U U_U$

- Coh is category generated from (directed multi)graph Ω under relations \sim
- isomorphisms $\Phi : \text{iiPoms} \leftrightarrow \text{Coh} : \Psi$ provided by
 - $\Phi(P) = [w]_{\sim}$, where w is any step decomposition of P ;
 - $\Psi([P_1 \dots P_n]_{\sim}) = P_1 * \dots * P_n$ (needs lemma)

Algebra?

- this is not cancellative:

$$a \bullet \begin{bmatrix} \bullet a \bullet \\ a \bullet \end{bmatrix} = a \bullet \begin{bmatrix} a \bullet \\ \bullet a \bullet \end{bmatrix} = \begin{bmatrix} a \bullet \\ a \bullet \end{bmatrix}$$

- “**categorical** concurrent Kleene algebra”?
- (what to do about subsumptions? **2-categories**?)

- ① Concurrent Kleene Algebra
- ② Birkhoff Duality & Path Objects
- ③ Geometric Realisation

Path Objects

Theorem

For every ipomset P there exists an HDA $\square^P := X$ such that $L(X) = \{P\}\downarrow$.

- the **path object** of P
- ad-hoc construction

Lemma (very useful!)

For any ipomset P and HDA X , $P \in L(X) \iff \exists f : \square^P \rightarrow X$.

- express **languages** using **morphisms**

Now Look At Those Down-Closed Subsets!

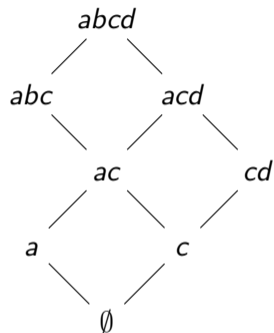
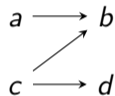

Now Look At Those Down-Closed Subsets!

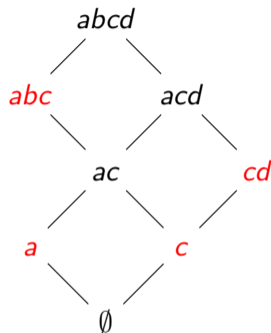
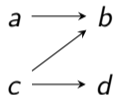

- **join-irreducibles** $\hat{=}$ principal downsets

Now Look At Those Down-Closed Subsets!

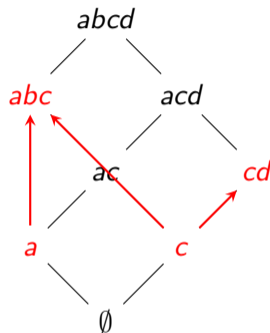
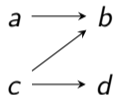

- **join-irreducibles** $\hat{=}$ principal downsets
- induced order **isomorphic** to P

Now Look At Those Down-Closed Subsets!

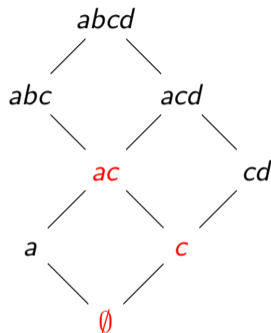
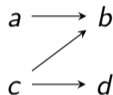

- join-irreducibles $\hat{=}$ principal downsets
- induced order isomorphic to P
- principal **strict** downsets **totally** ordered $\iff P$ **interval** order

Now Look At Those Down-Closed Subsets!

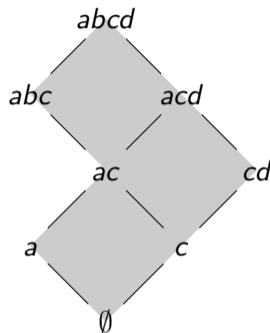
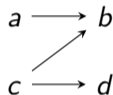

- join-irreducibles $\hat{=}$ principal downsets
- induced order isomorphic to P
- principal strict downsets totally ordered $\iff P$ interval order
- **Conjecture:** path object $\square^P \hat{=}$ **CAT0-closure** of subset lattice

- ① Concurrent Kleene Algebra
- ② Birkhoff Duality & Path Objects
- ③ Geometric Realisation

Geometric Realisation

Definition

A **precubical set** is a graded set $X = \{X_n\}_{n \geq 0}$ together with **face maps** $\delta_i^0, \delta_i^1 : X_n \rightarrow X_{n-1}$, for $i = 1, \dots, n$, satisfying $\delta_i^\nu \delta_j^\mu = \delta_{j-1}^\mu \delta_i^\nu$ for $i < j$.

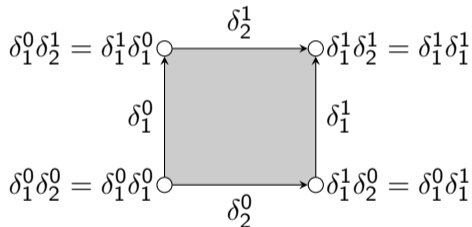

Definition

The **geometric realisation** of a precubical set X is the d-space $|X| = \bigsqcup_{n \geq 0} X_n \times \vec{I}^n / \sim$, where \sim is the equivalence generated by

$$(\delta_i^\nu x, (t_1, \dots, t_{n-1})) \sim (x, (t_1, \dots, t_{i-1}, \nu, t_{i+1}, \dots, t_{n-1})).$$

Geometric Realisation

Definition

The **geometric realisation** of a precubical set X is the d-space $|X| = \bigsqcup_{n \geq 0} X_n \times \vec{I}^n / \sim$, where \sim is the equivalence generated by

$$(\delta_i^\nu x, (t_1, \dots, t_{n-1})) \sim (x, (t_1, \dots, t_{i-1}, \nu, t_{i+1}, \dots, t_{n-1})).$$

- usual **coend** definition; left adjoint to **singular precubical set** functor
- actually, $|X|$ is an **lpo-space**

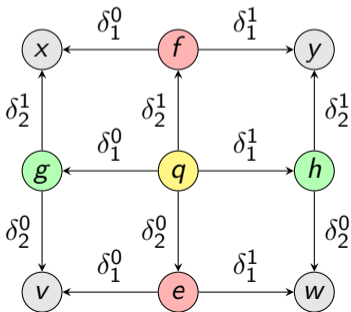
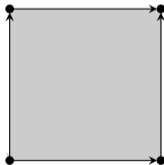

Dipaths in Geometric Realisations

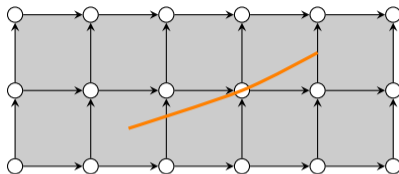

Let $p : \vec{I} \rightarrow |X|$ be a dipath in the geometric realisation of precubical set X .

- let $C_p = \{x \in X \mid \text{im}(p) \cap |x| \neq \emptyset\}$ – all cells touched by p
- organize C_p into a sequence $c_p = (x_1, \dots, x_m)$ s.t. $\forall i$:

$$x_i = \delta_+^0 x_{i+1} \quad \text{or} \quad x_{i+1} = \delta_+^1 x_i \quad (\text{iterated face maps})$$

Dipaths in Geometric Realisations

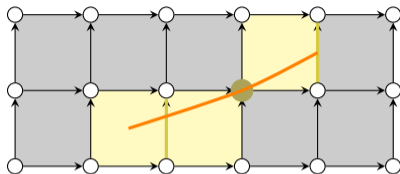

Let $p : \vec{I} \rightarrow |X|$ be a dipath in the geometric realisation of precubical set X .

- let $C_p = \{x \in X \mid \text{im}(p) \cap |x| \neq \emptyset\}$ – all cells touched by p
- organize C_p into a sequence $c_p = (x_1, \dots, x_m)$ s.t. $\forall i$:

$$x_i = \delta_+^0 x_{i+1} \quad \text{or} \quad x_{i+1} = \delta_+^1 x_i \quad (\text{iterated face maps})$$

\implies the **carrier sequence** of p : a **combinatorial path**

Lemma

- any combinatorial path c gives rise to dipath p_c (non-unique) with $c_{p_c} = c$
- if $c_p = c_q$, then p and q are **dihomotopic**

Combinatorial Homotopy

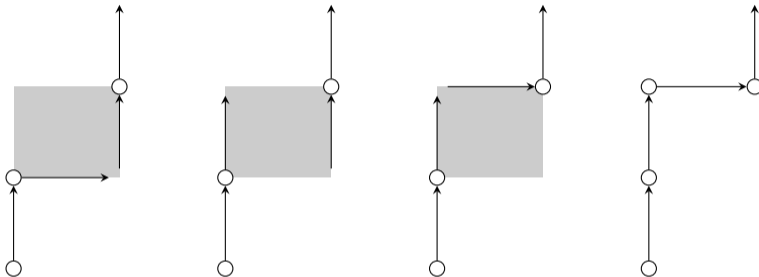

- equivalence relation on combinatorial paths generated by **local replacements**

Lemma

- *dipaths p, q are dihomotopic iff c_p and c_q are homotopic*
- *combinatorial paths c, d are homotopic iff p_c and p_d are dihomotopic*

Summing Up

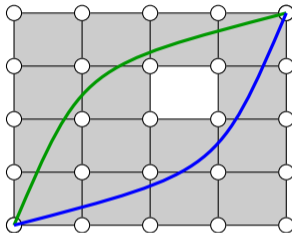

- precubical sets: combinatorial models of directed spaces
- linked to directed spaces via geometric realisation
- dipaths $\hat{=}$ combinatorial paths $\hat{=}$ executions
- dihomotopy $\hat{=}$ combinatorial homotopy $\hat{=}$ equivalence of executions

Combinatorial Homotopy vs Subsumption

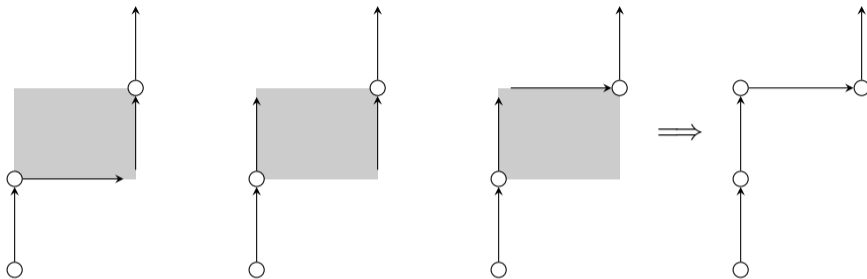

- subsumption \sqsubseteq : **preorder** generated by local replacements

\Rightarrow combinatorial homotopy \simeq is the equivalence relation generated by subsumption

Lemma

- $\alpha \sqsubseteq \beta \implies \text{ev}(\alpha) \sqsubseteq \text{ev}(\beta)$

??? $\alpha \simeq \beta \implies \text{ev}(\alpha) \text{ ??? } \text{ev}(\beta)$

Selected Bibliography

- L.Fajstrup. *Discovering spaces*. Homology Homotopy Appl. 2003
- L.Fajstrup. *Dipaths and dihomotopies in a cubical complex*. Adv.Appl.Math. 2005
- T.Hoare, B.Möller, G.Struth, I.Wehrman. *Concurrent Kleene algebra and its foundations*. J.Log.Alg.Prog. 2011
- C.Calk, L.Santocanale. *Complete congruences of completely distributive lattices*. RAMiCS 2024